

## Important notice

Dear Customer,

On 7 February 2017 the former NXP Standard Product business became a new company with the tradename **Nexperia**. Nexperia is an industry leading supplier of Discrete, Logic and PowerMOS semiconductors with its focus on the automotive, industrial, computing, consumer and wearable application markets

In data sheets and application notes which still contain NXP or Philips Semiconductors references, use the references to Nexperia, as shown below.

Instead of <http://www.nxp.com>, <http://www.philips.com/> or <http://www.semiconductors.philips.com/>, use <http://www.nexperia.com>

Instead of [sales.addresses@www.nxp.com](mailto:sales.addresses@www.nxp.com) or [sales.addresses@www.semiconductors.philips.com](mailto:sales.addresses@www.semiconductors.philips.com), use [salesaddresses@nexperia.com](mailto:salesaddresses@nexperia.com) (email)

Replace the copyright notice at the bottom of each page or elsewhere in the document, depending on the version, as shown below:

- © NXP N.V. (year). All rights reserved or © Koninklijke Philips Electronics N.V. (year). All rights reserved

Should be replaced with:

- © **Nexperia B.V. (year). All rights reserved.**

If you have any questions related to the data sheet, please contact our nearest sales office via e-mail or telephone (details via [salesaddresses@nexperia.com](mailto:salesaddresses@nexperia.com)). Thank you for your cooperation and understanding,

Kind regards,

Team Nexperia

# 74HCT221

Dual non-retriggerable monostable multivibrator with reset

Rev. 3 — 26 October 2016

Product data sheet

## 1. General description

The 74HCT221 is a dual non-retriggerable monostable multivibrator. Each multivibrator features edge-triggered inputs ( $\overline{nA}$  and  $nB$ ), either of which can be used as an enable input. Pulse triggering occurs at a particular voltage level and is not directly related to the transition time of the input pulse. Schmitt-trigger input circuitry for the  $nB$  inputs allow jitter-free triggering from inputs with slow transition rates, providing the circuit with excellent noise immunity. Once triggered, the outputs ( $nQ$ ,  $\overline{nQ}$ ) are independent of further transitions of  $\overline{nA}$  and  $nB$  inputs. The output pulse width is defined by the following relationship:  $t_W = 0.7 \times C_{EXT} \times R_{EXT}$ . The output pulses can be terminated by the active LOW reset inputs ( $\overline{nRD}$ ). Pulse width stability is achieved through internal compensation and is virtually independent of  $V_{CC}$  and temperature. In most applications pulse stability will only be limited by the accuracy of the external timing components. Inputs include clamp diodes. This enables the use of current limiting resistors to interface inputs to voltages in excess of  $V_{CC}$ .

## 2. Features and benefits

- Input levels:
  - ◆ For 74HCT221: TTL level
- Pulse width variance is typically less than  $\pm 5\%$
- Direct reset terminates output pulse
- Schmitt-trigger action on  $nB$  inputs
- ESD protection:
  - ◆ HBM JESD22-A114F exceeds 2000 V
  - ◆ MM JESD22-A115-A exceeds 200 V
- Specified from  $-40\text{ }^\circ\text{C}$  to  $+85\text{ }^\circ\text{C}$  and from  $-40\text{ }^\circ\text{C}$  to  $+125\text{ }^\circ\text{C}$

## 3. Ordering information

Table 1. Ordering information

Type number	Package			
	Temperature range	Name	Description	Version
74HCT221D	$-40\text{ }^\circ\text{C}$ to $+125\text{ }^\circ\text{C}$	SO16	plastic small outline package; 16 leads; body width 3.9 mm	SOT109-1



4. Functional diagram

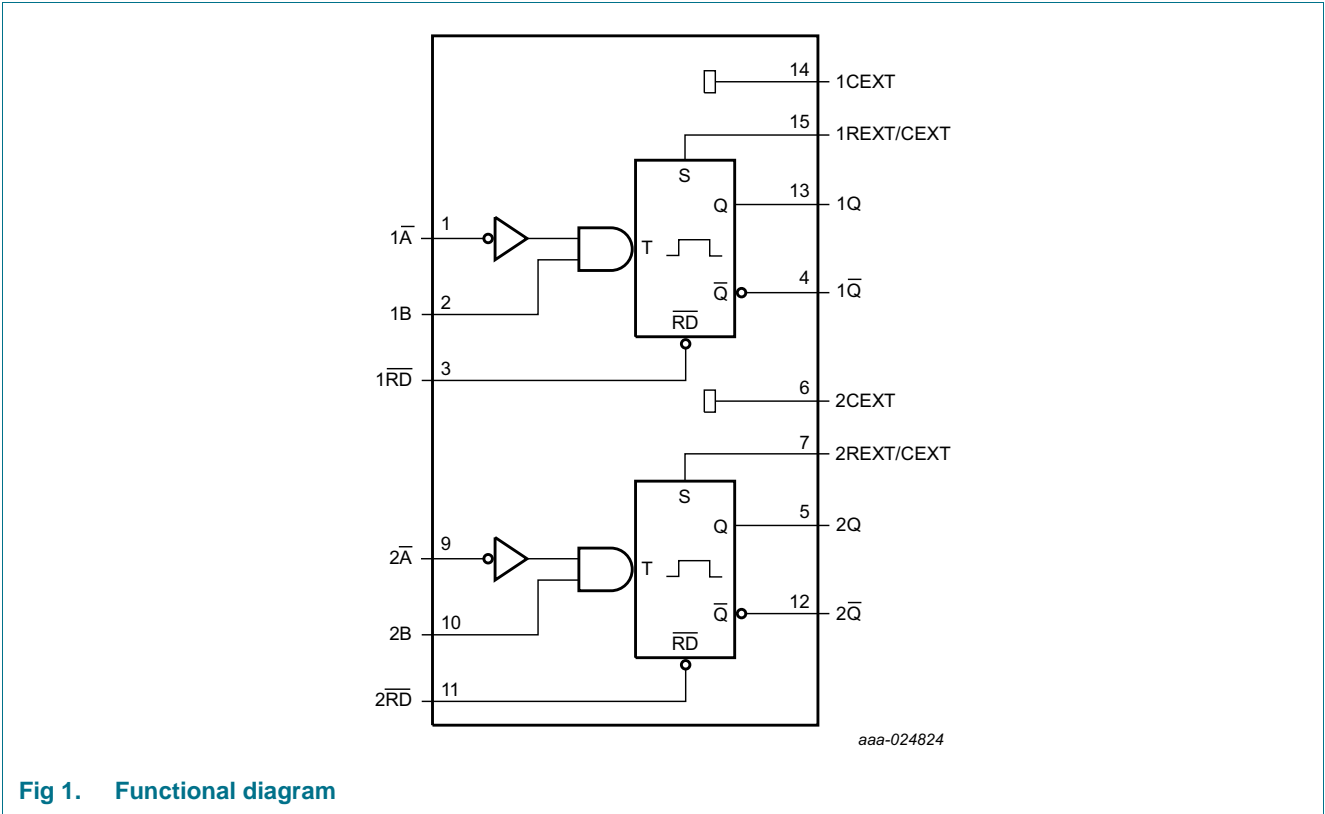

Fig 1. Functional diagram

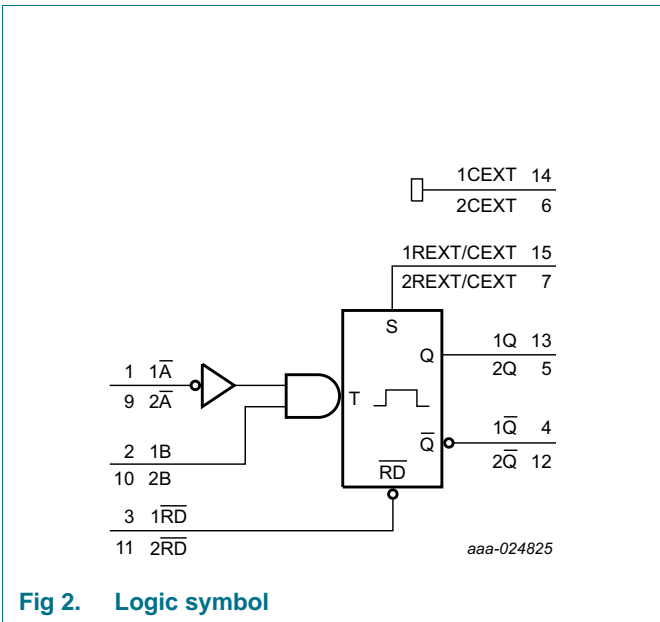

Fig 2. Logic symbol

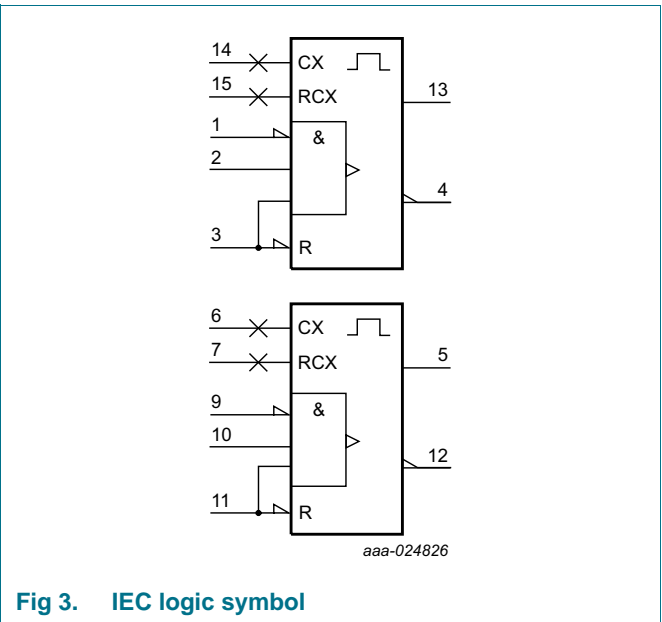

Fig 3. IEC logic symbol

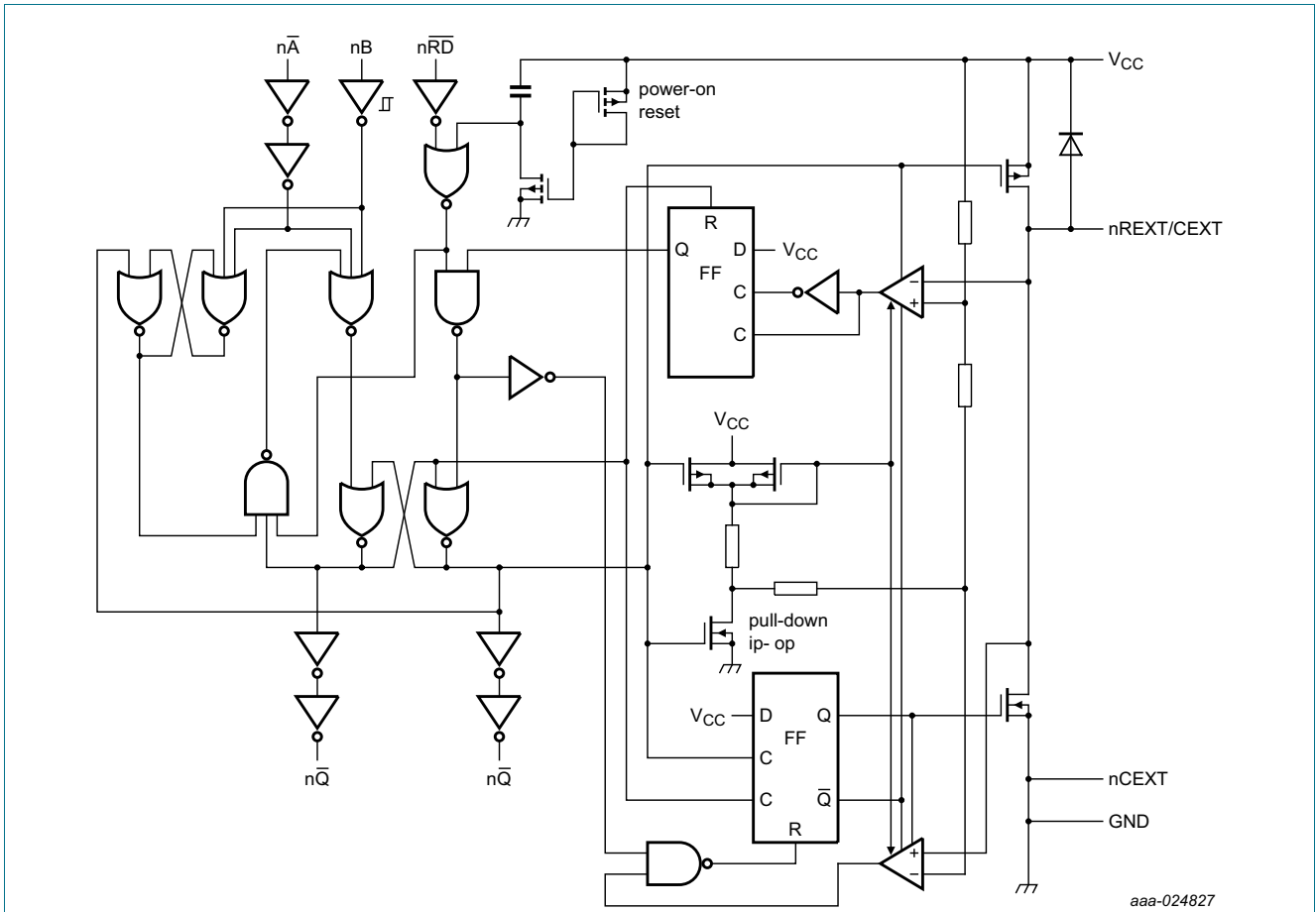
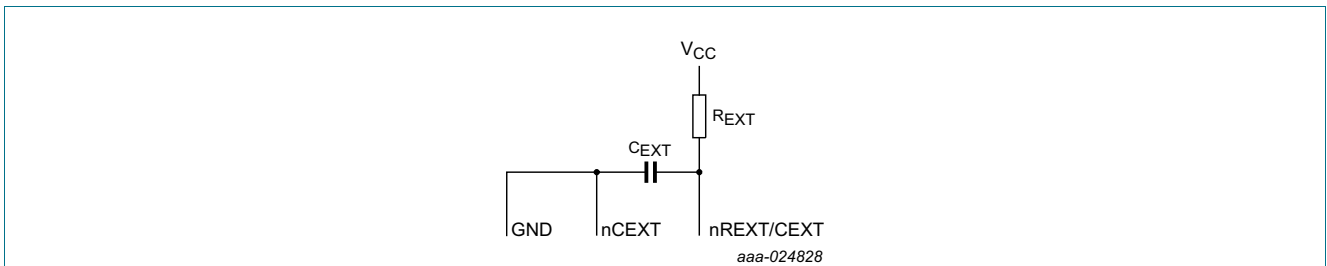

Fig 4. Logic diagram



It is recommended to connect pins nCEXT externally to the GND pin.

Fig 5. Timing component connections

## 5. Pinning information

### 5.1 Pinning

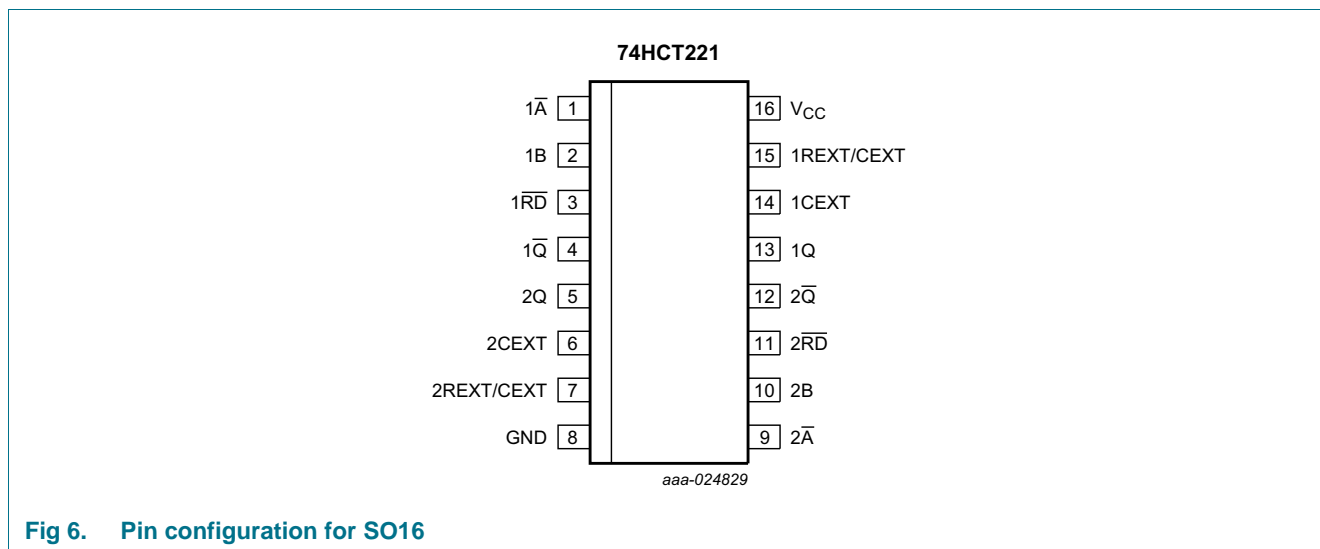

Fig 6. Pin configuration for SO16







### 5.2 Pin description

Table 2. Pin description



Symbol	Pin	Description
1Ā	1	negative-edge triggered input 1
1B	2	positive-edge triggered input 1
1RD̄	3	direct reset LOW and positive-edge triggered input 1
1Q̄	4	active LOW output 1
2Q	5	active HIGH output 2
2CEXT	6	external capacitor connection 2
2REXT/CEXT	7	external resistor and capacitor connection 2
GND	8	ground (0 V)
2Ā	9	negative-edge triggered input 2
2B	10	positive-edge triggered input 2
2RD̄	11	direct reset LOW and positive-edge triggered input 2
2Q̄	12	active LOW output 2
1Q	13	active HIGH output 1
1CEXT	14	external capacitor connection 1
1REXT/CEXT	15	external resistor and capacitor connection 1
V <sub>CC</sub>	16	supply voltage

## 6. Functional description

Table 3. Function table<sup>[1]</sup>

Input			Output	
nRD	nA	nB	nQ	nQ
L	X	X	L	H
X	H	X	L <sup>[2]</sup>	H <sup>[2]</sup>
X	X	L	L <sup>[2]</sup>	H <sup>[2]</sup>
H	L	↑		
H	↓	H		
↑	L	H	 <sup>[3]</sup>	 <sup>[3]</sup>

[1] H = HIGH voltage level; L = LOW voltage level; X = don't care; ↑ = LOW-to-HIGH transition; ↓ = HIGH-to-LOW transition;

 = one HIGH level output pulse;  = one LOW level output pulse.

[2] If the monostable was triggered before this condition was established, the pulse will continue as programmed.

[3] For this combination the reset input must be LOW and the following sequence must be used:

pin nA must be set HIGH or pin nB set LOW; then pin nA must be LOW and pin nB set HIGH. Now the reset input goes from LOW-to-HIGH and the device will be triggered.

## 7. Limiting values

Table 4. Limiting values

In accordance with the Absolute Maximum Rating System (IEC 60134). Voltages are referenced to GND (ground = 0 V).

Symbol	Parameter	Conditions	Min	Max	Unit
V <sub>CC</sub>	supply voltage		-0.5	+7	V
I <sub>IK</sub>	input clamping current	V <sub>I</sub> < -0.5 V or V <sub>I</sub> > V <sub>CC</sub> + 0.5 V	-	±20	mA
I <sub>OK</sub>	output clamping current	V <sub>O</sub> < -0.5 V or V <sub>O</sub> > V <sub>CC</sub> + 0.5 V	-	±20	mA
I <sub>O</sub>	output current	except for pins nREXT/CEXT; V <sub>O</sub> = -0.5 V to (V <sub>CC</sub> + 0.5 V)	-	±25	mA
I <sub>CC</sub>	supply current		-	50	mA
I <sub>GND</sub>	ground current		-50	-	mA
T <sub>stg</sub>	storage temperature		-65	+150	°C
P <sub>tot</sub>	total power dissipation	SO16 package <sup>[1]</sup>	-	500	mW

[1] For SO16 package: P<sub>tot</sub> derates linearly with 8 mW/K above 70 °C.

## 8. Recommended operating conditions

Table 5. Recommended operating conditions

Symbol	Parameter	Conditions	Min	Typ	Max	Unit
$V_{CC}$	supply voltage		4.5	5.0	5.5	V
$V_I$	input voltage		0	-	$V_{CC}$	V
$V_O$	output voltage		0	-	$V_{CC}$	V
$\Delta t/\Delta V$	input transition rise and fall rate	nA, $\overline{nRD}$ input				
		$V_{CC} = 4.5\text{ V}$	-	1.67	139	ns/V
$T_{amb}$	ambient temperature		-40	+25	+125	°C

## 9. Static characteristics

Table 6. Static characteristics

At recommended operating conditions; voltages are referenced to GND (ground = 0 V).

Symbol	Parameter	Conditions	25 °C			-40 °C to +85 °C		-40 °C to +125 °C		Unit
			Min	Typ	Max	Min	Max	Min	Max	
$V_{IH}$	HIGH-level input voltage	$V_{CC} = 4.5\text{ V to }5.5\text{ V}$	2.0	1.6	-	2.0	-	2.0	-	V
$V_{IL}$	LOW-level input voltage	$V_{CC} = 4.5\text{ V to }5.5\text{ V}$	-	1.2	0.8	-	0.8	-	0.8	V
$V_{OH}$	HIGH-level output voltage	$V_I = V_{IH}$ or $V_{IL}$ ; $V_{CC} = 4.5\text{ V}$								
		$I_O = -20\ \mu\text{A}$	4.4	4.5	-	4.4	-	4.4	-	V
		$I_O = -4\text{ mA}$	3.98	4.32	-	3.84	-	3.7	-	V
$V_{OL}$	LOW-level output voltage	$V_I = V_{IH}$ or $V_{IL}$ ; $V_{CC} = 4.5\text{ V}$								
		$I_O = 20\ \mu\text{A}$	-	0	0.1	-	0.1	-	0.1	V
		$I_O = 4.0\text{ mA}$	-	0.15	0.26	-	0.33	-	0.4	V
$I_I$	input leakage current	$V_I = V_{CC}$ or GND; $V_{CC} = 5.5\text{ V}$	-	-	$\pm 0.1$	-	$\pm 1.0$	-	$\pm 1.0$	$\mu\text{A}$
$I_{CC}$	supply current	$V_I = V_{CC}$ or GND; $I_O = 0\text{ A}$ ; $V_{CC} = 5.5\text{ V}$	-	-	8.0	-	80	-	160	$\mu\text{A}$
$\Delta I_{CC}$	additional supply current	per input pin; $I_O = 0\text{ A}$ ; $V_I = V_{CC} - 2.1\text{ V}$ ; other inputs at $V_{CC}$ or GND; $V_{CC} = 4.5\text{ V to }5.5\text{ V}$								
		pin nB	-	30	108	-	135	-	147	$\mu\text{A}$
		pins $\overline{nA}$ , $\overline{nRD}$	-	50	180	-	225	-	245	$\mu\text{A}$
$C_I$	input capacitance		-	3.5	-	-	-	-	-	pF

## 10. Dynamic characteristics

**Table 7. Dynamic characteristics**

Voltages are referenced to GND (ground = 0 V);  $C_L = 50$  pF unless otherwise specified; for test circuit see [Figure 15](#).

Symbol	Parameter	Conditions	25 °C			-40 °C to +85 °C		-40 °C to +125 °C		Unit
			Min	Typ	Max	Min	Max	Min	Max	
t <sub>PLH</sub>	LOW to HIGH propagation delay	C <sub>EXT</sub> = 0 pF; R <sub>EXT</sub> = 5 kΩ; see <a href="#">Figure 7</a> and <a href="#">Figure 8</a>								
		n $\bar{A}$ , n $\bar{RD}$ to nQ (trigger)								
		V <sub>CC</sub> = 4.5 V	-	30	50	-	63	-	75	ns
		V <sub>CC</sub> = 5 V; C <sub>L</sub> = 15 pF	-	36	-	-	-	-	-	ns
		nB to nQ (trigger)								
		V <sub>CC</sub> = 4.5 V	-	24	42	-	53	-	63	ns
		V <sub>CC</sub> = 5 V; C <sub>L</sub> = 15 pF	-	36	-	-	-	-	-	ns
		n $\bar{RD}$ to n $\bar{Q}$ (reset)								
V <sub>CC</sub> = 4.5 V	-	31	51	-	64	-	77	ns		
V <sub>CC</sub> = 5 V; C <sub>L</sub> = 15 pF	-	36	-	-	-	-	-	ns		
t <sub>PHL</sub>	HIGH to LOW propagation delay	C <sub>EXT</sub> = 0 pF; R <sub>EXT</sub> = 5 kΩ; see <a href="#">Figure 7</a> and <a href="#">Figure 8</a>								
		n $\bar{A}$ to n $\bar{Q}$ (trigger)								
		V <sub>CC</sub> = 4.5 V	-	26	44	-	55	-	75	ns
		V <sub>CC</sub> = 5 V; C <sub>L</sub> = 15 pF	-	32	-	-	-	-	-	ns
		nB to n $\bar{Q}$ (trigger)								
		V <sub>CC</sub> = 4.5 V	-	21	35	-	44	-	53	ns
		V <sub>CC</sub> = 5 V; C <sub>L</sub> = 15 pF	-	32	-	-	-	-	-	ns
		n $\bar{RD}$ to n $\bar{Q}$ (trigger)								
		V <sub>CC</sub> = 4.5 V	-	26	43	-	54	-	65	ns
		V <sub>CC</sub> = 5 V; C <sub>L</sub> = 15 pF	-	32	-	-	-	-	-	ns
		n $\bar{RD}$ to nQ (reset)								
		V <sub>CC</sub> = 4.5 V	-	26	43	-	54	-	65	ns
V <sub>CC</sub> = 5 V; C <sub>L</sub> = 15 pF	-	32	-	-	-	-	-	ns		
t <sub>t</sub>	transition time	V <sub>CC</sub> = 4.5 V; see <a href="#">Figure 7</a> <sup>[1]</sup>	-	7	15	-	19	-	22	ns

**Table 7. Dynamic characteristics ...continued**

Voltages are referenced to GND (ground = 0 V);  $C_L = 50$  pF unless otherwise specified; for test circuit see [Figure 15](#).

Symbol	Parameter	Conditions	25 °C			-40 °C to +85 °C		-40 °C to +125 °C		Unit
			Min	Typ	Max	Min	Max	Min	Max	
t <sub>w</sub>	pulse width	n $\bar{A}$ LOW; nB HIGH; (trigger); see <a href="#">Figure 7</a>								
		V <sub>CC</sub> = 4.5 V	20	13	-	25	-	30	-	ns
		n $\bar{RD}$ LOW; see <a href="#">Figure 10</a>								
		V <sub>CC</sub> = 4.5 V	22	13	-	28	-	33	-	ns
		nQ HIGH and n $\bar{Q}$ LOW; see <a href="#">Figure 8</a>								
		V <sub>CC</sub> = 5 V; C <sub>EXT</sub> = 100 nF; R <sub>EXT</sub> = 10 k $\Omega$	630	700	770	602	798	595	805	$\mu$ s
		nQ or n $\bar{Q}$ (trigger); see <a href="#">Figure 8</a>								
		V <sub>CC</sub> = 4.5 V; C <sub>EXT</sub> = 28 pF; R <sub>EXT</sub> = 2 k $\Omega$	-	140	-	-	-	-	-	ns
		V <sub>CC</sub> = 4.5 V; C <sub>EXT</sub> = 1 nF; R <sub>EXT</sub> = 2 k $\Omega$	-	1.5	-	-	-	-	-	$\mu$ s
		V <sub>CC</sub> = 4.5 V; C <sub>EXT</sub> = 1 nF; R <sub>EXT</sub> = 10 k $\Omega$	-	7	-	-	-	-	-	$\mu$ s
t <sub>rec</sub>	recovery time	n $\bar{RD}$ to n $\bar{A}$ , nB; see <a href="#">Figure 11</a>	20	12	-	25	-	30	-	ns
R <sub>EXT</sub>	external timing resistor	V <sub>CC</sub> = 5.0 V; see <a href="#">Figure 13</a>	2	-	1000	-	-	-	-	k $\Omega$
C <sub>EXT</sub>	external timing capacitor	V <sub>CC</sub> = 5.0 V; see <a href="#">Figure 13</a>	no limits							pF

**Table 7. Dynamic characteristics ...continued**

*Voltages are referenced to GND (ground = 0 V);  $C_L = 50 \text{ pF}$  unless otherwise specified; for test circuit see [Figure 15](#).*

Symbol	Parameter	Conditions	25 °C			-40 °C to +85 °C		-40 °C to +125 °C		Unit
			Min	Typ	Max	Min	Max	Min	Max	
$C_{PD}$	power dissipation capacitance	per monostable; $V_I = \text{GND to } V_{CC} - 1.5 \text{ V}$	-	96	-	-	-	-	-	pF

[1]  $t_t$  is the same as  $t_{THL}$  and  $t_{TLH}$

[2]  $C_{PD}$  is used to determine the dynamic power dissipation ( $P_D$  in  $\mu\text{W}$ ).

$$P_D = C_{PD} \times V_{CC}^2 \times f_i + \sum(C_L \times V_{CC}^2 \times f_o) + 0.33 \times C_{EXT} \times V_{CC}^2 \times f_o + D \times 28 \times V_{CC}$$

$f_i$  = input frequency in MHz;

$f_o$  = output frequency in MHz;

$D$  = duty factor in %;

$C_L$  = output load capacitance in pF;

$V_{CC}$  = supply voltage in V;

$C_{EXT}$  = timing capacitance in pF;

$\sum(C_L \times V_{CC}^2 \times f_o)$  sum of outputs.

## 11. Waveforms and graphs

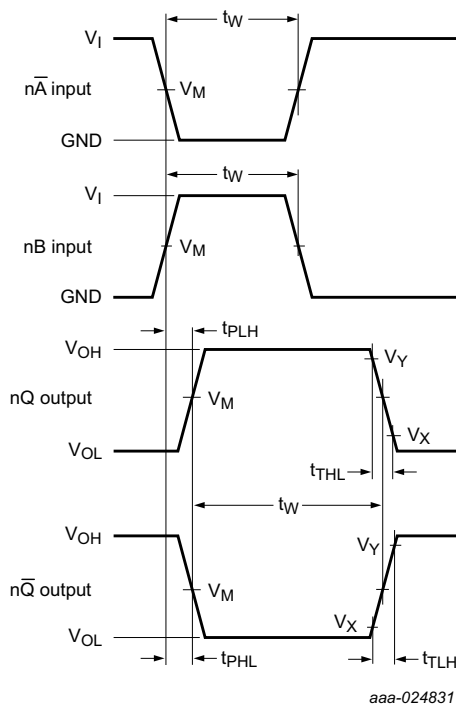

Measurement points are given in [Table 8](#).

$V_{OL}$  and  $V_{OH}$  are typical voltage output levels that occur with the output load.

**Fig 7. Propagation delay from input ( $\overline{nA}$ ,  $nB$ ) to output ( $nQ$ ,  $\overline{nQ}$ ),  $\overline{nA}$ ,  $nB$  pulse widths and output transition times**

Table 8. Measurement points

Input	Output		
$V_M$	$V_M$	$V_X$	$V_Y$
1.3 V	1.3 V	$0.1V_{CC}$	$0.9V_{CC}$

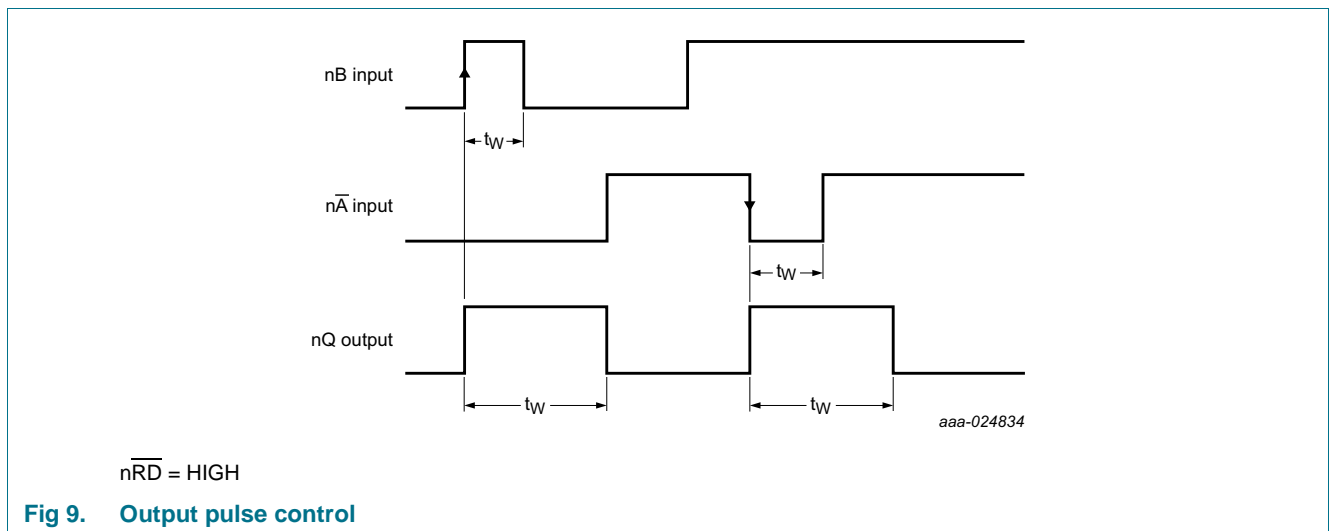
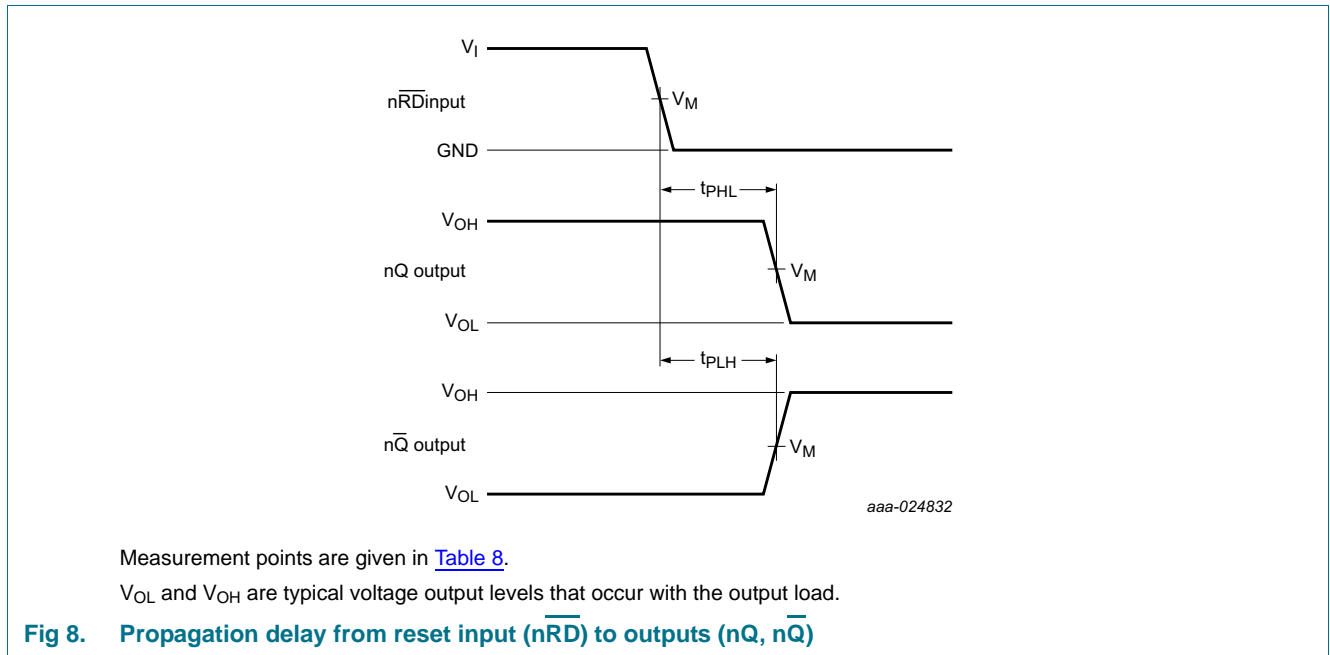

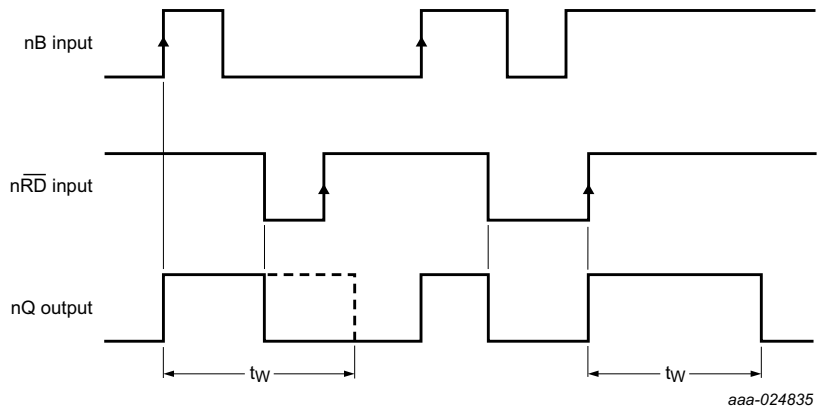

$\overline{nA} = \text{LOW}$

Fig 10. Output pulse control using reset input  $\overline{nRD}$

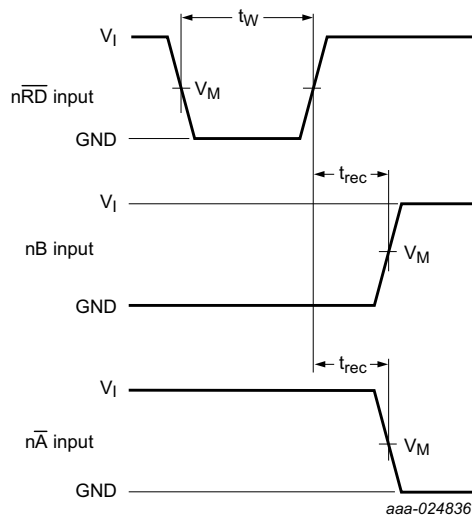

Measurement points are given in [Table 8](#).

Fig 11. Reset input ( $\overline{nRD}$ ) to inputs  $\overline{nA}$  or nB recovery times

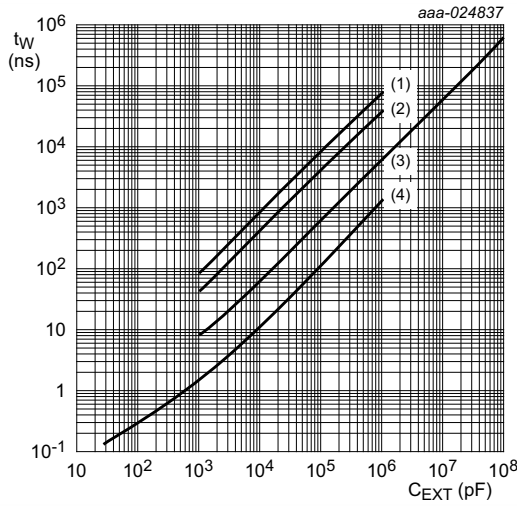

- $V_{CC} = 4.5\text{ V}; T_{amb} = 25\text{ }^{\circ}\text{C}.$
- (1)  $R_{EXT} = 100\text{ k}\Omega$
  - (2)  $R_{EXT} = 50\text{ k}\Omega$
  - (3)  $R_{EXT} = 10\text{ k}\Omega$
  - (4)  $R_{EXT} = 2\text{ k}\Omega$

Fig 12. Typical output pulse width as a function of the external capacitor

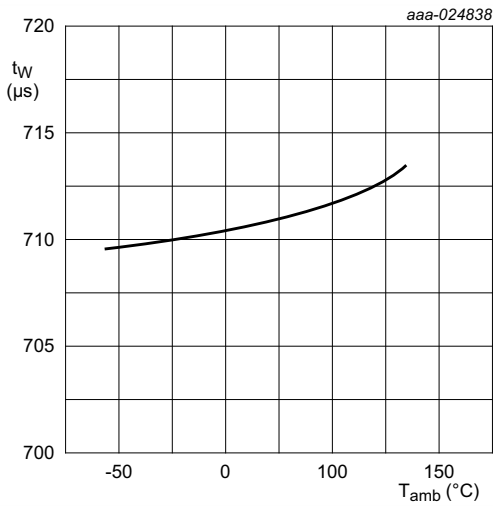

$C_{EXT} = 0.1\text{ }\mu\text{F}; R_{EXT} = 10\text{ k}\Omega.; V_{CC} = 5.0\text{ V}$

Fig 13. Typical output pulse width as a function of the ambient temperature

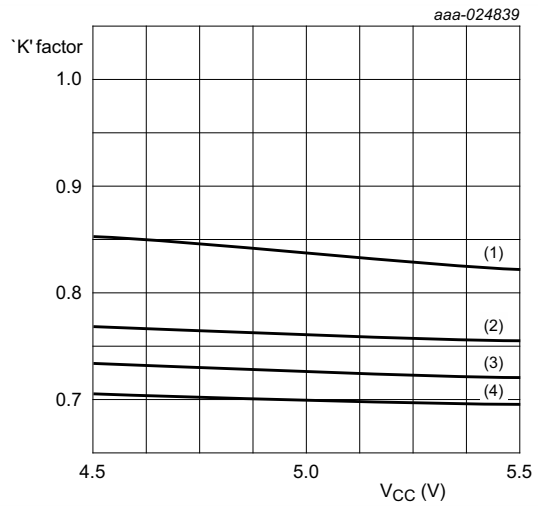

- $R_{EXT} = 10\text{ k}\Omega; T_{amb} = 25\text{ }^{\circ}\text{C}.$
- (1)  $C_{EXT} = 0.001\text{ }\mu\text{F}$
  - (2)  $C_{EXT} = 0.01\text{ }\mu\text{F}$
  - (3)  $C_{EXT} = 0.1\text{ }\mu\text{F}$
  - (4)  $C_{EXT} = 1\text{ }\mu\text{F}$

Fig 14. "K" factor as function of the supply voltage

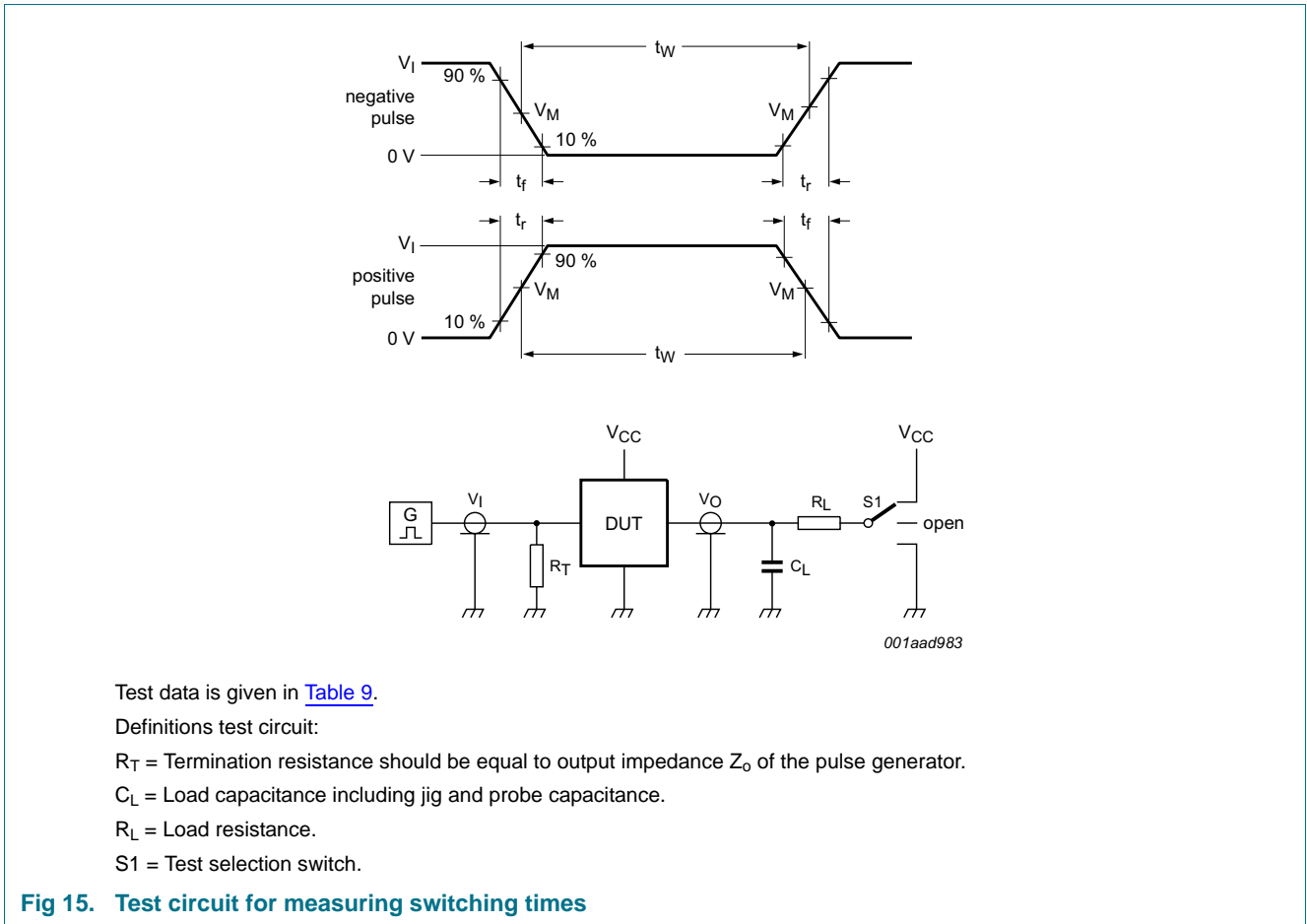

**Table 9. Test data**

Input		Load		S1 position
$V_I$	$t_r, t_f$	$C_L$	$R_L$	$t_{PHL}, t_{PLH}$
3 V	6 ns	15 pF, 50 pF	1 kΩ	open

## 12. Application information

### 12.1 Power-down considerations

A large capacitor  $C_{EXT}$  may cause problems when powering-down the monostable due to the energy stored in this capacitor. When a system containing this device is powered-down or a rapid decrease of  $V_{CC}$  to zero occurs, the monostable may sustain damage, due to the capacitor discharging through the input protection diodes. To avoid this possibility, use a damping diode ( $D_{EXT}$ ) preferably a germanium or Schottky type diode able to withstand large current surges and connect as shown in [Figure 16](#).

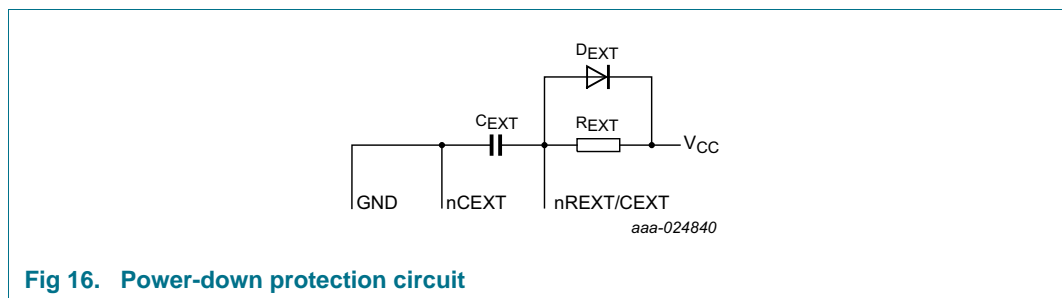

Fig 16. Power-down protection circuit

13. Package outline

SO16: plastic small outline package; 16 leads; body width 3.9 mm

SOT109-1

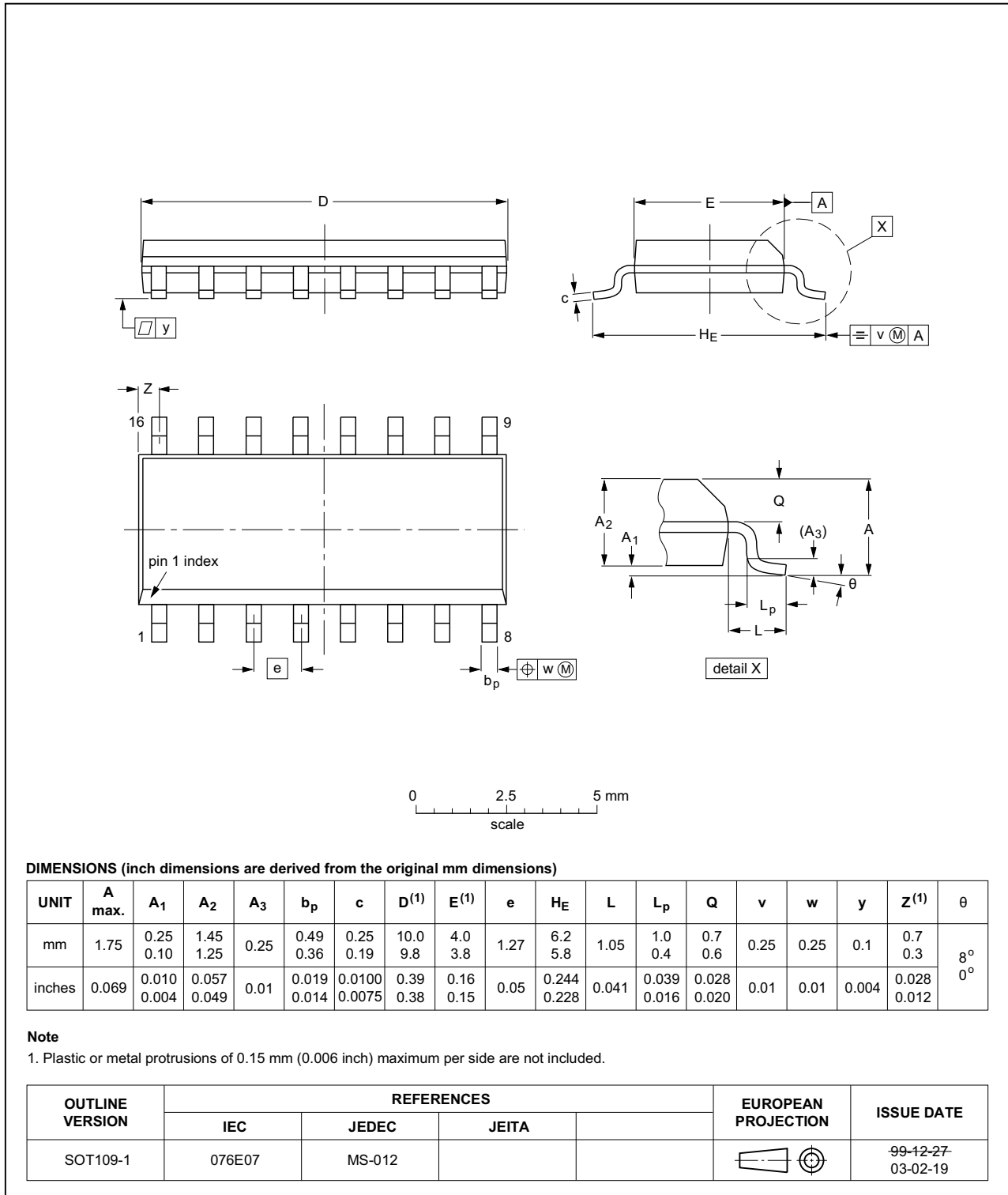

Fig 17. Package outline SOT109-1 (SO16)

## 14. Abbreviations

Table 10. Abbreviations

Acronym	Abbreviation
CMOS	Complementary Metal Oxide Semiconductor
DUT	Device Under Test
ESD	ElectroStatic Discharge
HBM	Human Body Model
MM	Machine Model

## 15. Revision history

Table 11. Revision history

Document ID	Release date	Data sheet status	Change notice	Supersedes
74HCT221 v.3	20161026	Product data sheet	-	74HC_HCT221 v.2
Modifications:	<ul style="list-style-type: none"> <li>The format of this data sheet has been redesigned to comply with the new identity guidelines of NXP Semiconductors.</li> <li>Legal texts have been adapted to the new company name where appropriate.</li> <li>Type numbers 74HC221N, 74HC221D, 74HC221DB and 74HCT221N removed.</li> </ul>			
74HC_HCT221 v.2	19901201	Product specification	-	-

## 16. Legal information

### 16.1 Data sheet status

Document status <sup>[1][2]</sup>	Product status <sup>[3]</sup>	Definition
Objective [short] data sheet	Development	This document contains data from the objective specification for product development.
Preliminary [short] data sheet	Qualification	This document contains data from the preliminary specification.
Product [short] data sheet	Production	This document contains the product specification.

[1] Please consult the most recently issued document before initiating or completing a design.

[2] The term 'short data sheet' is explained in section "Definitions".

[3] The product status of device(s) described in this document may have changed since this document was published and may differ in case of multiple devices. The latest product status information is available on the Internet at URL <http://www.nxp.com>.

### 16.2 Definitions

**Draft** — The document is a draft version only. The content is still under internal review and subject to formal approval, which may result in modifications or additions. NXP Semiconductors does not give any representations or warranties as to the accuracy or completeness of information included herein and shall have no liability for the consequences of use of such information.

**Short data sheet** — A short data sheet is an extract from a full data sheet with the same product type number(s) and title. A short data sheet is intended for quick reference only and should not be relied upon to contain detailed and full information. For detailed and full information see the relevant full data sheet, which is available on request via the local NXP Semiconductors sales office. In case of any inconsistency or conflict with the short data sheet, the full data sheet shall prevail.

**Product specification** — The information and data provided in a Product data sheet shall define the specification of the product as agreed between NXP Semiconductors and its customer, unless NXP Semiconductors and customer have explicitly agreed otherwise in writing. In no event however, shall an agreement be valid in which the NXP Semiconductors product is deemed to offer functions and qualities beyond those described in the Product data sheet.

### 16.3 Disclaimers

**Limited warranty and liability** — Information in this document is believed to be accurate and reliable. However, NXP Semiconductors does not give any representations or warranties, expressed or implied, as to the accuracy or completeness of such information and shall have no liability for the consequences of use of such information. NXP Semiconductors takes no responsibility for the content in this document if provided by an information source outside of NXP Semiconductors.

In no event shall NXP Semiconductors be liable for any indirect, incidental, punitive, special or consequential damages (including - without limitation - lost profits, lost savings, business interruption, costs related to the removal or replacement of any products or rework charges) whether or not such damages are based on tort (including negligence), warranty, breach of contract or any other legal theory.

Notwithstanding any damages that customer might incur for any reason whatsoever, NXP Semiconductors' aggregate and cumulative liability towards customer for the products described herein shall be limited in accordance with the *Terms and conditions of commercial sale* of NXP Semiconductors.

**Right to make changes** — NXP Semiconductors reserves the right to make changes to information published in this document, including without limitation specifications and product descriptions, at any time and without notice. This document supersedes and replaces all information supplied prior to the publication hereof.

**Suitability for use** — NXP Semiconductors products are not designed, authorized or warranted to be suitable for use in life support, life-critical or safety-critical systems or equipment, nor in applications where failure or malfunction of an NXP Semiconductors product can reasonably be expected to result in personal injury, death or severe property or environmental damage. NXP Semiconductors and its suppliers accept no liability for inclusion and/or use of NXP Semiconductors products in such equipment or applications and therefore such inclusion and/or use is at the customer's own risk.

**Applications** — Applications that are described herein for any of these products are for illustrative purposes only. NXP Semiconductors makes no representation or warranty that such applications will be suitable for the specified use without further testing or modification.

Customers are responsible for the design and operation of their applications and products using NXP Semiconductors products, and NXP Semiconductors accepts no liability for any assistance with applications or customer product design. It is customer's sole responsibility to determine whether the NXP Semiconductors product is suitable and fit for the customer's applications and products planned, as well as for the planned application and use of customer's third party customer(s). Customers should provide appropriate design and operating safeguards to minimize the risks associated with their applications and products.

NXP Semiconductors does not accept any liability related to any default, damage, costs or problem which is based on any weakness or default in the customer's applications or products, or the application or use by customer's third party customer(s). Customer is responsible for doing all necessary testing for the customer's applications and products using NXP Semiconductors products in order to avoid a default of the applications and the products or of the application or use by customer's third party customer(s). NXP does not accept any liability in this respect.

**Limiting values** — Stress above one or more limiting values (as defined in the Absolute Maximum Ratings System of IEC 60134) will cause permanent damage to the device. Limiting values are stress ratings only and (proper) operation of the device at these or any other conditions above those given in the Recommended operating conditions section (if present) or the Characteristics sections of this document is not warranted. Constant or repeated exposure to limiting values will permanently and irreversibly affect the quality and reliability of the device.

**Terms and conditions of commercial sale** — NXP Semiconductors products are sold subject to the general terms and conditions of commercial sale, as published at <http://www.nxp.com/profile/terms>, unless otherwise agreed in a valid written individual agreement. In case an individual agreement is concluded only the terms and conditions of the respective agreement shall apply. NXP Semiconductors hereby expressly objects to applying the customer's general terms and conditions with regard to the purchase of NXP Semiconductors products by customer.

**No offer to sell or license** — Nothing in this document may be interpreted or construed as an offer to sell products that is open for acceptance or the grant, conveyance or implication of any license under any copyrights, patents or other industrial or intellectual property rights.

**Export control** — This document as well as the item(s) described herein may be subject to export control regulations. Export might require a prior authorization from competent authorities.

**Non-automotive qualified products** — Unless this data sheet expressly states that this specific NXP Semiconductors product is automotive qualified, the product is not suitable for automotive use. It is neither qualified nor tested in accordance with automotive testing or application requirements. NXP Semiconductors accepts no liability for inclusion and/or use of non-automotive qualified products in automotive equipment or applications.

In the event that customer uses the product for design-in and use in automotive applications to automotive specifications and standards, customer (a) shall use the product without NXP Semiconductors' warranty of the product for such automotive applications, use and specifications, and (b) whenever customer uses the product for automotive applications beyond

NXP Semiconductors' specifications such use shall be solely at customer's own risk, and (c) customer fully indemnifies NXP Semiconductors for any liability, damages or failed product claims resulting from customer design and use of the product for automotive applications beyond NXP Semiconductors' standard warranty and NXP Semiconductors' product specifications.

**Translations** — A non-English (translated) version of a document is for reference only. The English version shall prevail in case of any discrepancy between the translated and English versions.

## 16.4 Trademarks

Notice: All referenced brands, product names, service names and trademarks are the property of their respective owners.

## 17. Contact information

For more information, please visit: <http://www.nxp.com>

For sales office addresses, please send an email to: [salesaddresses@nxp.com](mailto:salesaddresses@nxp.com)

18. Contents

1 General description . . . . . 1

2 Features and benefits . . . . . 1

3 Ordering information . . . . . 1

4 Functional diagram . . . . . 2

5 Pinning information . . . . . 4

5.1 Pinning . . . . . 4

5.2 Pin description . . . . . 4

6 Functional description . . . . . 5

7 Limiting values . . . . . 5

8 Recommended operating conditions . . . . . 6

9 Static characteristics . . . . . 6

10 Dynamic characteristics . . . . . 7

11 Waveforms and graphs . . . . . 9

12 Application information . . . . . 14

12.1 Power-down considerations . . . . . 14

13 Package outline . . . . . 15

14 Abbreviations . . . . . 16

15 Revision history . . . . . 16

16 Legal information . . . . . 17

16.1 Data sheet status . . . . . 17

16.2 Definitions . . . . . 17

16.3 Disclaimers . . . . . 17

16.4 Trademarks . . . . . 18

17 Contact information . . . . . 18

18 Contents . . . . . 19

Please be aware that important notices concerning this document and the product(s) described herein, have been included in section 'Legal information'.

© NXP Semiconductors N.V. 2016. All rights reserved.

For more information, please visit: <http://www.nxp.com>  
 For sales office addresses, please send an email to: [salesaddresses@nxp.com](mailto:salesaddresses@nxp.com)

Date of release: 26 October 2016  
 Document identifier: 74HCT221